

Centre No.						Paper Reference					Surname	Initial(s)		
Candidate No.						5	5	2	3	/	0	4	Signature	

Paper Reference(s)

5523/04

Edexcel GCSE

Mathematics A – 1387

Paper 4 (Calculator)

Intermediate Tier

Friday 9 November 2007 – Morning

Time: 2 hours

Examiner's use only

--	--	--

Team Leader's use only

--	--	--



Materials required for examination

Ruler graduated in centimetres and millimetres, protractor, compasses, pen, HB pencil, eraser, calculator. Tracing paper may be used.

Items included with question papers

Nil

Instructions to Candidates

In the boxes above, write your centre number, candidate number, your surname, initials and signature. Check that you have the correct question paper.

Answer ALL the questions in the spaces provided in this question paper.

You must NOT write on the formulae page. Anything you write on the formulae page will gain NO credit.

If you need more space to complete your answer to any question, use additional answer sheets.

Information for Candidates

The marks for individual questions and the parts of questions are shown in round brackets: e.g. (2).

There are 26 questions in this question paper. The total mark for this paper is 100.

There are 24 pages in this question paper. Any blank pages are indicated.

Calculators may be used.

If your calculator does not have a π button, take the value of π to be 3.142 unless the question instructs otherwise.

Advice to Candidates

Show all stages in any calculations.

Work steadily through the paper. Do not spend too long on one question.

If you cannot answer a question, leave it and attempt the next one.

Return at the end to those you have left out.

This publication may be reproduced only in accordance with Edexcel Limited copyright policy. ©2007 Edexcel Limited.

Printer's Log No.

N29111A

W850/R5523/57570 6/6/6/3/



Turn over

edexcel 
advancing learning, changing lives

GCSE Mathematics 1387/8

Formulae: Intermediate Tier

**You must not write on this formulae page.
Anything you write on this formulae page will gain NO credit.**

Area of trapezium = $\frac{1}{2}(a + b)h$

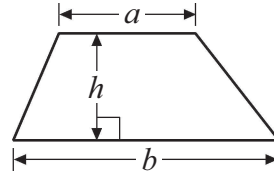

Volume of prism = area of cross section \times length

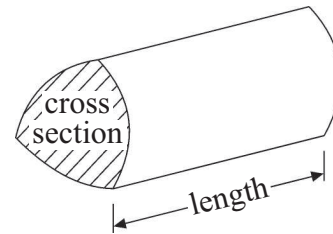

Answer ALL TWENTY SIX questions.

Write your answers in the spaces provided.

You must write down all stages in your working.

1. Plain tiles cost 28p each.
Patterned tiles cost £9.51 each.

Julie buys 450 plain tiles and 15 patterned tiles.

- (a) Work out the total cost of the tiles.

£.....
(3)

- (b) Express 15 as a fraction of 450
Give your answer in its simplest form.

.....
(2)

Fred lays the tiles.
He charges £360 plus VAT at 17.5%.

- (c) Work out the total amount that Fred charges.

£.....
(3)

(Total 8 marks)

Q1



2. Jamie travelled 20 km from his home to his friend's house. Jamie then spent some time at his friend's house before returning home. Here is the travel graph for part of Jamie's journey.

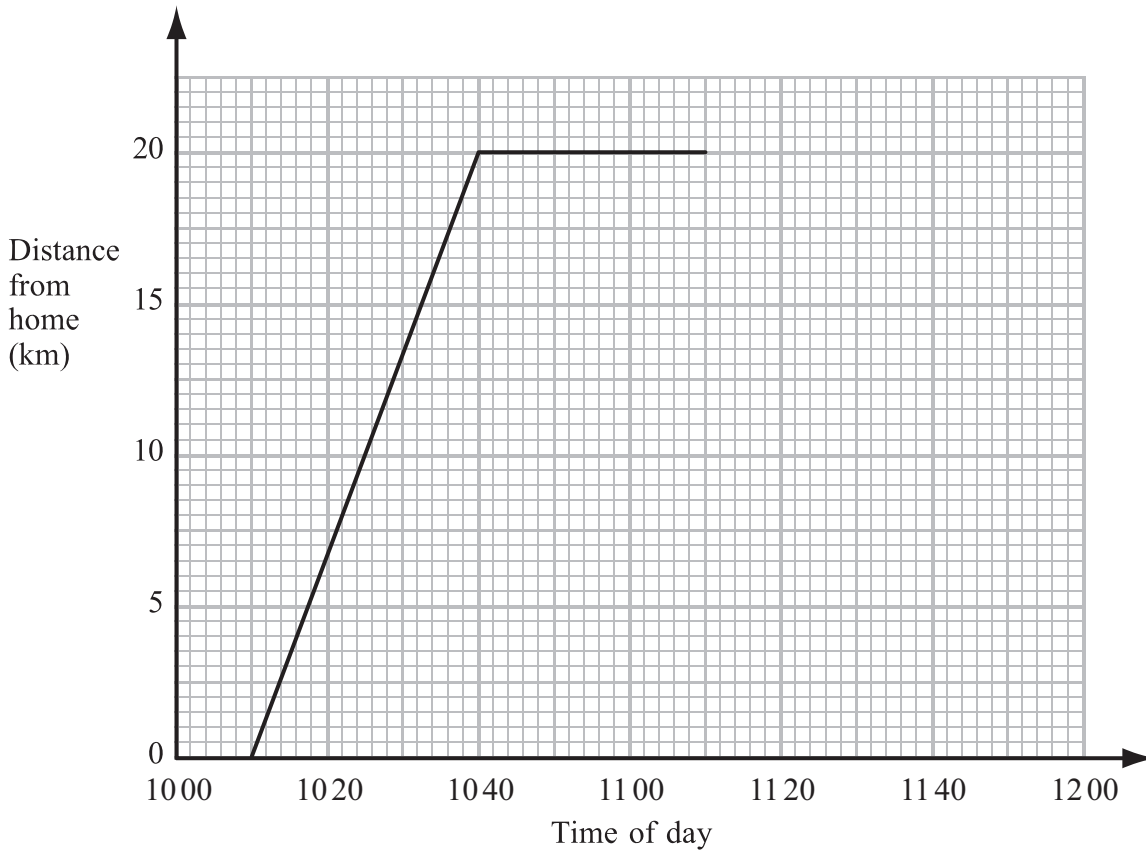

- (a) Write down the time that Jamie left home.

.....
(1)

- (b) Write down Jamie's distance from home at 10 20

..... km
(1)

Jamie left his friend's house at 11 10 to return home.

- (c) Work out the time in minutes Jamie spent at his friend's house.

..... minutes
(1)

Jamie returned home at a steady speed. He arrived home at 11 50

- (d) Complete the travel graph.

(1)



(e) Work out Jamie's average speed on his journey from his home to his friend's house. Give your answer in kilometres per hour.

..... kilometres per hour
(2)

(Total 6 marks)

Q2

3. (a) Solve $x + x + x = 15$

$x =$
(1)

(b) Solve $4y + 1 = 12$

$y =$
(2)

(c) Simplify $cd + 2cd$

.....
(1)

(d) Simplify $4p + 3q - p - 4q$

.....
(2)

(Total 6 marks)

Q3



4.

Diagram **NOT** accurately drawn

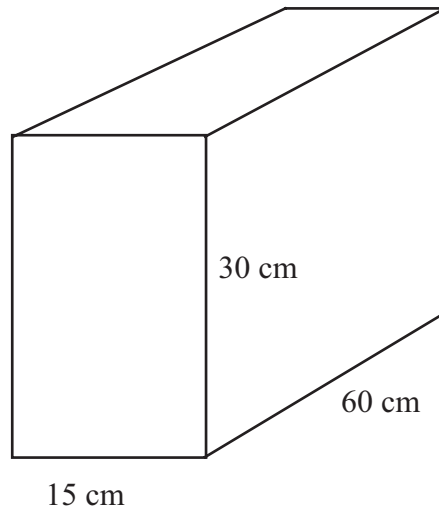

The diagram shows a cuboid.

The length of the cuboid is 60 cm.

The width of the cuboid is 15 cm.

The height of the cuboid is 30 cm.

Work out the volume of the cuboid.

..... cm³

(Total 2 marks)

Q4



5.

Diagram **NOT** accurately drawn

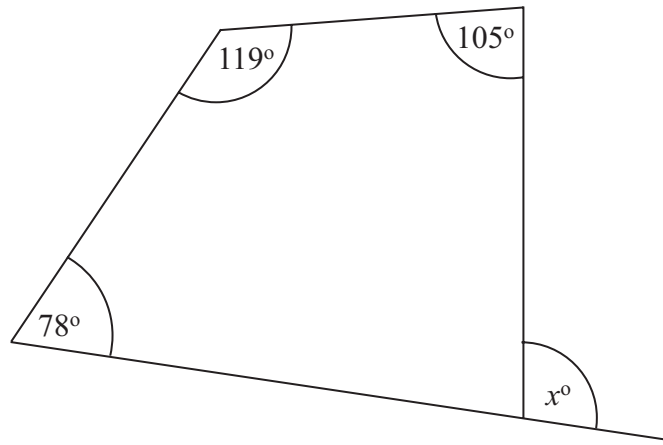

Work out the value of x .

$x = \dots\dots\dots$

(Total 3 marks)

Q5



6. Mr Irvine has a farm.

The table gives information about the number of animals on his farm.

Animal	Frequency	
Cow	15	
Hen	12	
Pig	5	
Sheep	28	

Complete the accurate pie chart to show this information.

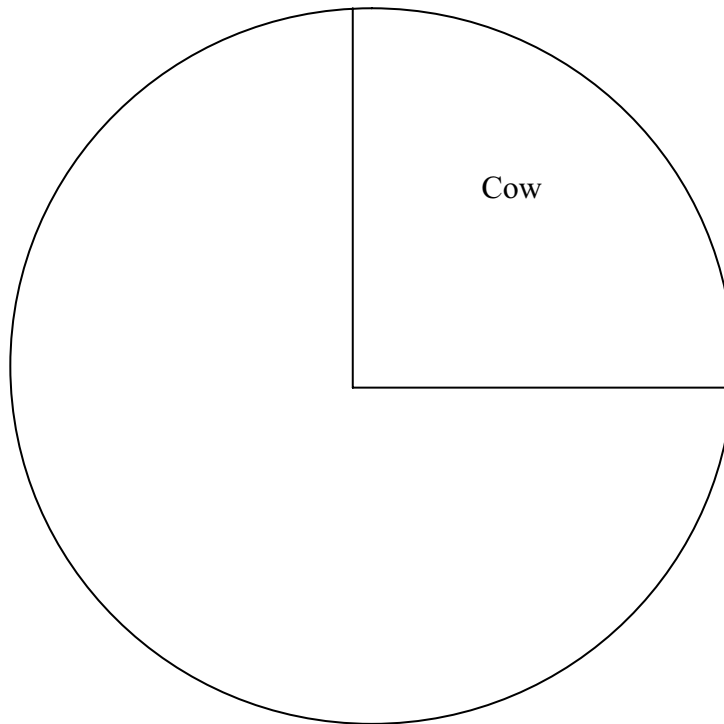

Q6

(Total 4 marks)



7. Use your calculator to work out the value of $\sqrt{20.25} + 1.65^2$

(a) Write down all the figures on your calculator display.

.....
(2)

(b) Write your answer to part (a) correct to 1 decimal place.

.....
(1)

(Total 3 marks)

Q7

8. The cost of 1.5 kg of peaches is £0.84

The total cost of 3 kg of peaches and 2 kg of apples is £2.34

Work out the cost of 1 kg of apples.

.....

(Total 3 marks)

Q8



9.

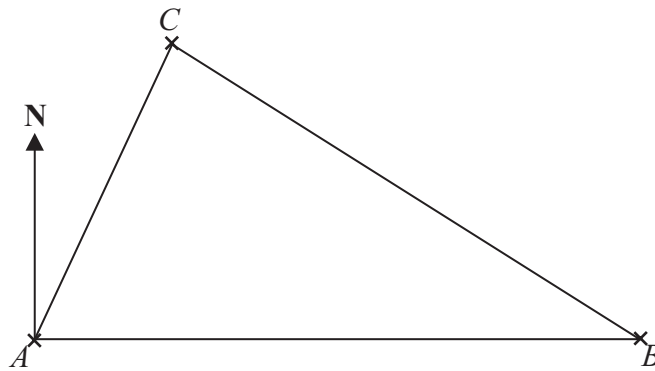

The crosses on the diagram show the positions of three places *A*, *B* and *C*.

The scale of the diagram is 1 cm to 5 km.

(a) Find the actual distance between *A* and *B*.

..... km
(1)

(b) Measure the bearing of *C* from *A*.

.....
°
(1)

D is a fourth place.

The actual distance of *D* from *A* is 20 km.

The bearing of *D* from *A* is 115° .

(c) Mark with a cross (×) the position of *D* on the diagram. Label the point *D*.

(2)

Q9

(Total 4 marks)



10. (a) Solve $4y + 3 = 2y + 9$

$y = \dots\dots\dots$
(2)

(b) Solve $5(t - 3) = 8$

$t = \dots\dots\dots$
(2)

(Total 4 marks)

Q10

11. In April 2004, the population of the European Community was 376 million.

In April 2005, the population of the European Community was 451 million.

(a) Work out the percentage increase in population.
Give your answer correct to 1 decimal place.

$\dots\dots\dots\%$
(3)

In April 2004, the area of the European Community was 3.2 million km².

In April 2005, the area of the European Community increased by $\frac{3}{8}$

(b) Work out the area of the European Community in April 2005.

$\dots\dots\dots$ million km²
(2)

(Total 5 marks)

Q11



12.

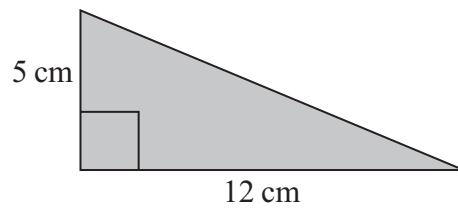
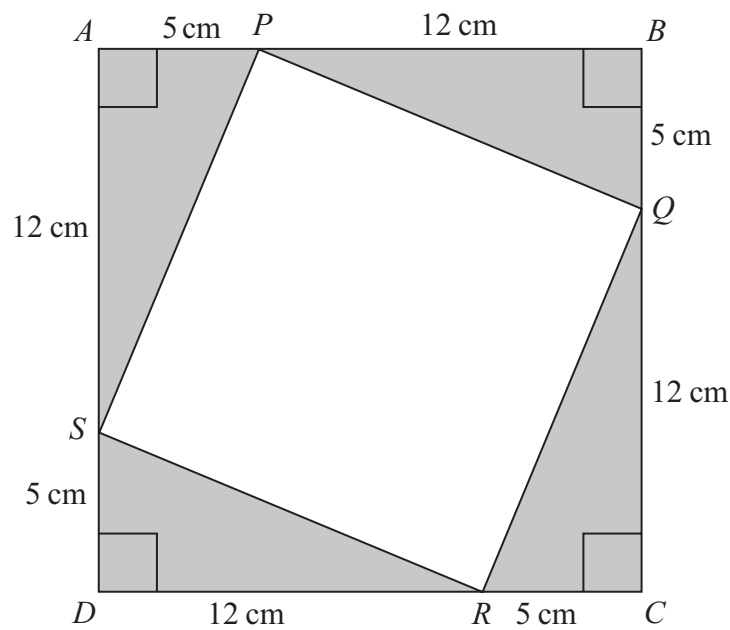

Diagram **NOT** accurately drawn

(a) Work out the area of the triangle.

..... cm²
(2)

Diagram **NOT** accurately drawn



4 copies of the triangle and the quadrilateral $PQRS$ are used to make the square $ABCD$.

(b) Work out the area of the quadrilateral $PQRS$.

..... cm^2
(3)

(Total 5 marks)

Q12

13. The table shows some expressions.
In each expression, n is a whole number.

$3n^2$	$9n$	$3 \times 6n$	$3 + 6n$	$(3n)^2$	$n + 9$

Tick (✓) the box underneath each of the **three** expressions which are always multiples of 9

(Total 3 marks)

Q13

14. On July 1st 2004, Jack invested £2000 at 5% per annum compound interest.

Work out the value of Jack's investment on July 1st 2006

£

(Total 3 marks)

Q14



15. Ali found out the number of rooms in each of 40 houses in a town. He used the information to complete the frequency table.

Number of Rooms	Frequency	
4	4	
5	7	
6	10	
7	12	
8	5	
9	2	

Ali said that the mode is 9
Ali is wrong.

- (a) Explain why.

.....
.....

(1)

- (b) Calculate the mean number of rooms.

.....

(3)



- (c) Beccy found out the number of rooms in each of 80 houses in the same town. She used the information to complete the frequency table below.

Number of Rooms	Frequency
4	10
5	12
6	15
7	18
8	17
9	8

Find the median number of rooms.

.....
(1)

- (d) The median number of rooms in Ali's table is 6

Which of the two medians, Ali's or Beccy's, is more likely to give the more reliable estimate for the median number of rooms for a house in this town?

.....

Give a reason for your answer.

.....

.....

(1)

Q15

(Total 6 marks)



16.

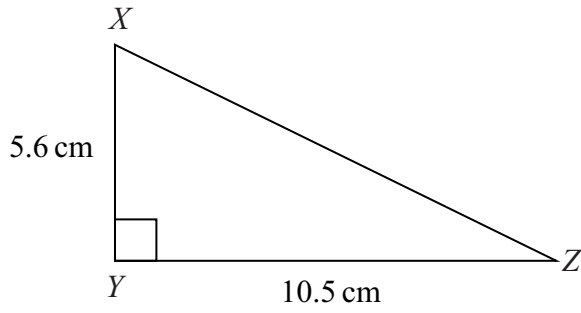

Diagram **NOT** accurately drawn

In the triangle XYZ

$$XY = 5.6 \text{ cm}$$

$$YZ = 10.5 \text{ cm}$$

$$\text{angle } XYZ = 90^\circ$$

Work out the length of XZ .

..... cm

Q16

(Total 3 marks)



17.

Diagram **NOT** accurately drawn

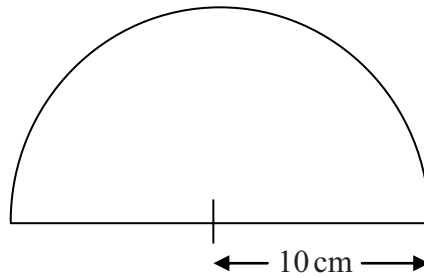

The diagram shows a semicircle.
The radius of the semicircle is 10 cm.

Calculate the area of the semicircle.
Give your answer correct to 3 significant figures.
State the units of your answer.

.....

Q17

(Total 3 marks)

18. Write 720 as a product of its prime factors.

.....

Q18

(Total 2 marks)



19. $A = \frac{h(x+10)}{2}$

$A = 27$

$h = 4$

Work out the value of x .

$x = \dots\dots\dots$

Q19

(Total 3 marks)



20.

Month	Jan	Feb	Mar	Apr	May	Jun
Number of Televisions	1240	1270	1330	1300	1330	x

The table shows the number of televisions sold in a shop in the first five months of 2006.

(a) Work out the first 3-month moving average for the information in the table.

.....
(2)

The fourth 3-month moving average of the number of televisions sold in 2006 is 1350
The number of televisions sold in the shop in June was x .

(b) Work out the value of x .

$x =$
(2)

(Total 4 marks)

Q20



21. (a) Complete the table of values for $y = 2x^2 - 4x$

x	-2	-1	0	1	2	3
y	16		0			6

(2)

(b) On the grid, draw the graph of $y = 2x^2 - 4x$ for values of x from -2 to 3

(2)

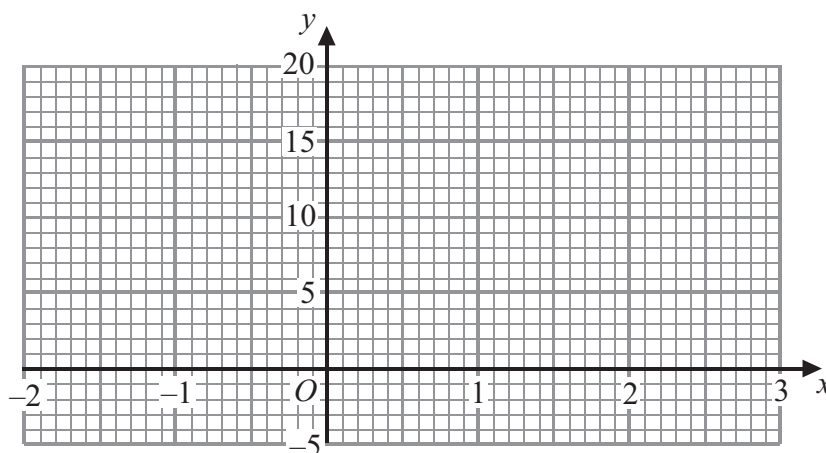

(c) (i) On the same axes, draw the straight line $y = 2.5$

(ii) Write down the values of x for which $2x^2 - 4x = 2.5$

.....
(2)

(Total 6 marks)

Q21



22. In a sale, normal prices are reduced by 25%.
The sale price of a saw is £12.75

Calculate the normal price of the saw.

£

Q22

(Total 3 marks)

23. Work out

$$\frac{2 \times 2.2 \times 10^{12} \times 1.5 \times 10^{12}}{2.2 \times 10^{12} - 1.5 \times 10^{12}}$$

Give your answer in standard form correct to 3 significant figures.

.....

Q23

(Total 3 marks)



24. Solve

$$3x + y = 8$$

$$4x + 2y = 9$$

$x = \dots\dots\dots$

$y = \dots\dots\dots$

Q24

(Total 3 marks)

25.

Diagram NOT accurately drawn

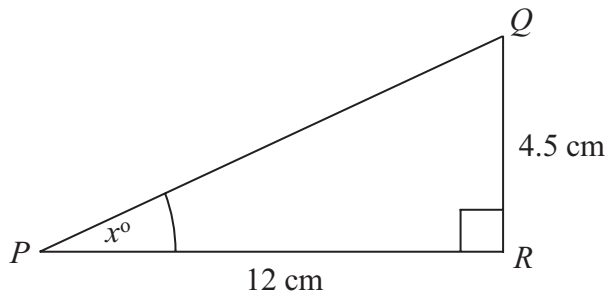

PQR is a right-angled triangle.

$PR = 12$ cm.

$QR = 4.5$ cm.

Angle $PRQ = 90^\circ$.

Work out the value of x .

Give your answer correct to one decimal place.

$x = \dots\dots\dots$

Q25

(Total 3 marks)



26.

Diagram NOT accurately drawn

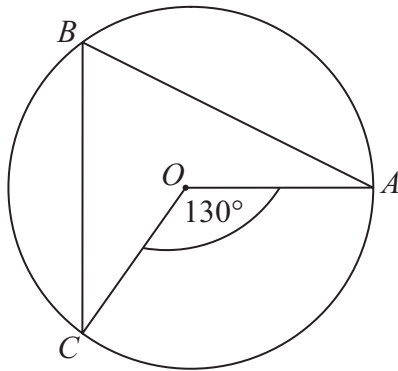

In the diagram, O is the centre of the circle.
 A , B and C are points on the circle.

Angle $COA = 130^\circ$.

(i) Find the size of angle CBA .

.....
 o

(ii) Give a reason for your answer.

.....

(Total 2 marks)

Q26

TOTAL FOR PAPER: 100 MARKS

END

